



BROTHER'S
SCHOOL

Guía N°3 de Lenguaje y Comunicación
1° Básico









Asignatura: Lenguaje y
Comunicación.

Profesoras:
Francisca Salinas
María José Soto

OBJETIVO DE LA CLASE: Identificar los sonidos que componen las palabras, reconociendo, separando y combinando sus fonemas y sílabas.

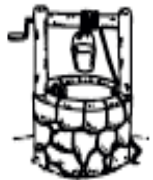
Instrucciones: Junto a tus papitos lean la siguiente guía y respondan. Diles que te ayuden a escribir tu respuesta.

1.- **Une** cada dibujo con la vocal que tenga su nombre.

	a		a
	e		e
	i		i
13	o		o
	u		u











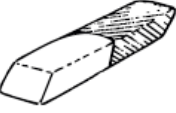

**BROTHER'S
SCHOOL**

**Guía N°3 de Lenguaje y Comunicación
1° Básico**

Asignatura: Lenguaje y
Comunicación.

Profesoras:
Francisca Salinas
María José Soto

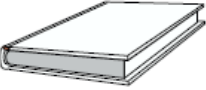
2.- **Une** cada dibujo con las vocales que tenga su nombre.

	o a		e a
	i o		i a
	e a		a e
	a i		o a
	e o		a a

¿Cómo te resultó la actividad? Pinta y responde



Fácil

Porque _____



me costó poco

Porque _____



me costó mucho

Porque _____
